

SF15/PPF15

SF25/PPF25

SF30/PPF30

SF38/PPF38

SF45/PPF45

SF60/PPF60

SF65/PPF65

SF85/PPF85

SF200/PPF200

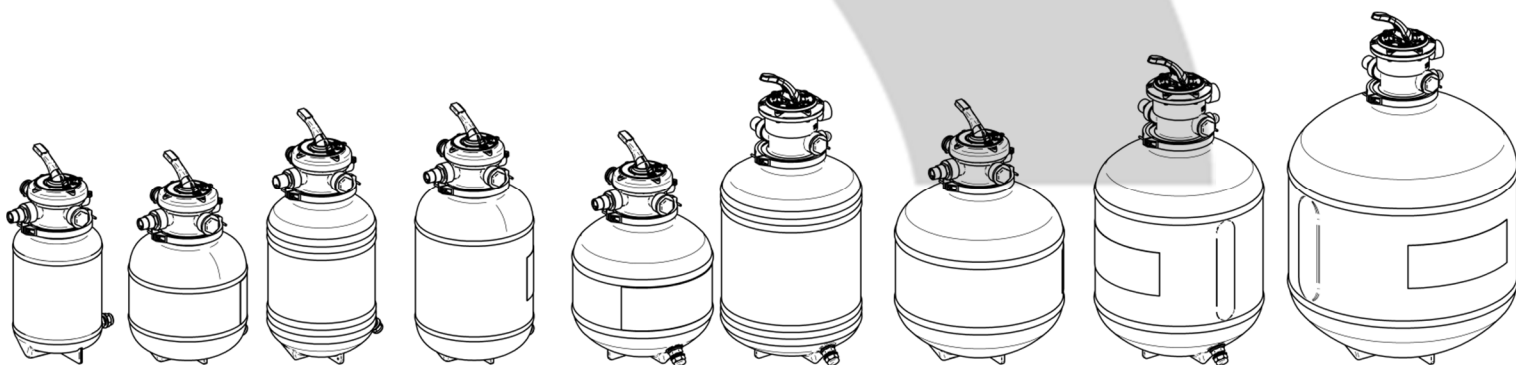

CUSTOMER MANUAL (EN)

EN

1	Content organisation and consultation methods.....	4
2	General warnings and user information.....	6
3	Product presentation.	8
4	Technical specifications and features.....	9
5	Installation.	10
6	Operations and use.	19
7	User instructions.....	20
8	Routine, scheduled and extraordinary maintenance.	22
9	Troubleshooting.....	24
10	Retail and spare parts and relevant documentation.....	26

1 Content organisation and consultation methods.

1.1 Symbols.

⚠ Indicates hazardous situations and warnings. Carefully read the parts of the user manual marked with this symbol.

⚡ Indicates that work must not be performed on live electrical devices. This work may only begin after all suitable safety measures required by current international and/or national regulations are taken.

1.2 Notes on graphics.

Used the following printing types:

- *glossary of terms: italic;*
- the words "product", "customer manual" and "installation manual" highlighted.

1.3 Glossary.

1. *Pump*: electromechanical device used to move water (Fig. 1).

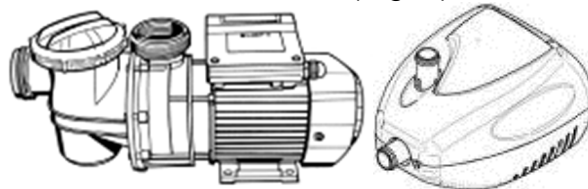

Fig. 1

2. *Inlet*: product input (Fig. 2, IN).

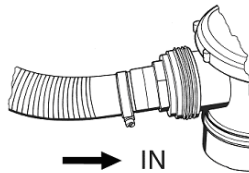

Fig. 2

3. *Outlet*: the product's exit (Fig. 3, OUT).

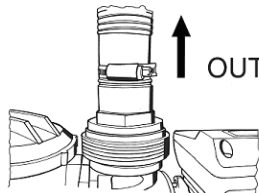

Fig. 3

4. *Flowrate*: the amount of fluid (water) that crosses a section in a unit of time.

5. *Head*: this is the maximum distance that a *pump* can lift water for.

6. *Flooded*: if the *pump* is positioned at a level below the water level to be sucked.

7. *Dry operation*: means the product's operation without water.

8. *Residual Current Device*: (RCD) also called fuse, it is an electro-technical device able to cut off the circuit in the event of fault.

9. *Hydraulic parts*: components used to create the system where the product is used (pipes, valves, couplings, hose connections, etc.).

10. *Pool*: artificial tank filled with water general intended for swimming or other aquatic activities.

11. *Filter*: a device where the water flowing in order to retain and/or eliminate the solid particles suspended.

12. *Filter media*: filtering material, contained in the *filter*, responsible for filtering.

13. *Skimmer*: a *filter* that keeps the *swimming pool* surface clean.

14. *Power plug*: mechanical connector that can be inserted in a complementary electrical socket (*power outlet*).

15. *Maximum working pressure*: maximum pressure the product is able to sustain during operations.

16. *Multifunctional valve*: device used to regulate the water flow (Fig. 4, # 1).

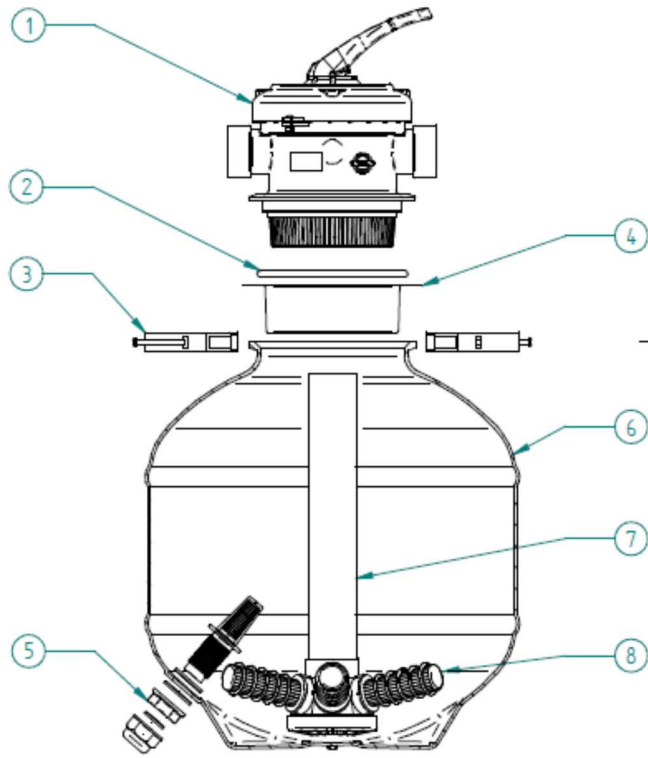

Fig. 4

2 General warnings and user information.

2.1 Returns.

In the event of defects, faults and malfunctions, the product must be returned to the deal with the completed claim report, where applicable.

2.2 General and safety warnings.

2.2.1 General warnings.

SHOTT International srl continuously strives to improve its products. We trust the user will understand the technical modifications **SHOTT International srl** reserves the right.

SHOTT International srl is not liable for any damages due to improper product use.

Carefully read and keep the user manual.

In order to increase energy savings, only use the product when necessary.

⚠ The following paragraphs include all the instructions necessary to best use the product according to your needs and to independently perform the cleaning and maintenance operations that this type of product requires. The references (#) in parentheses correspond to the parts indicated in the diagram (see Fig. 5, Fig. 6).

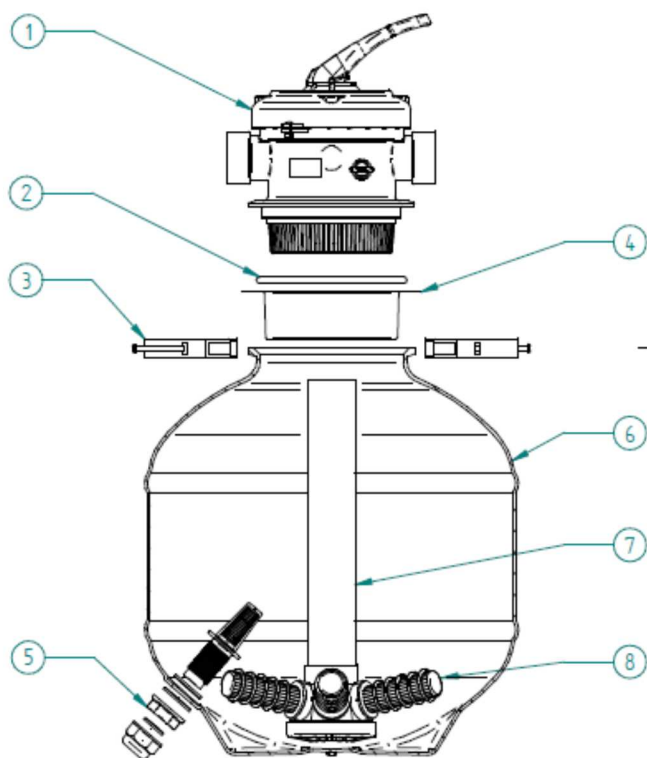

Fig. 5

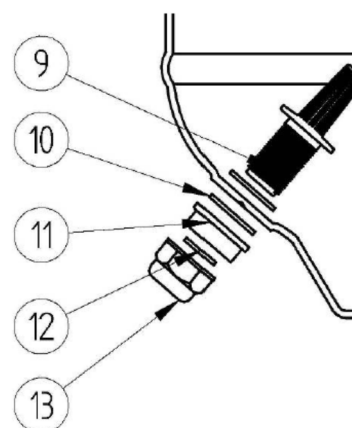

Fig. 6

⚠ Upon product receipt and/or purchase, check packaging integrity. The product must be accompanied by the user manual. The user manual must be complete.

In the event of malfunctions, consult the user manual and, if necessary, contact specialised technicians.

Failure to observe the instructions in this user manual immediately null and voids the warranty.

⚠ Follow carefully what is reported next so that you will use the product respecting the most common safety rules and remember that it is necessary to have a proper pool *pump* to be able to use the product.

⚠ Respect current regulations regarding accident prevention.

⚠ Due to the complex nature of the cases treated, the installation, user and maintenance instructions contained in this customer manual do not seek to examine all possible and imaginable cases of service and maintenance. Should you require additional instruction or have specific problems, please do not hesitate to contact the distributor or the product manufacturer directly.

2.2.2 Safety warnings.

⚠ The product is not suited for people (even children) who suffer from physical, sensorial or mental handicaps or people who do not have sufficient experience or training unless instructed on product use and assisted by a person in charge of their safety. Supervise children to ensure they do not play with the device.

- ⚡ Never put your hands in the water if the product (*pump*) is in operation.
- ⚡ The product (*pump*) must never be operated in the *swimming pool* when people are present.
- ⚡ Do not submerge the product in water.
- ⚡ Be sure to disconnect the *power plug* from the *power outlet* before operating on the product (*pump*).
- ⚠ Attention to the *inlet/outlet* points because they can trap parts of the body and/or hair and cause serious personal injuries and even death.
- ⚠ It is compulsory to check that the inlet ends are not blocked.
- ⚠ *Pumps, filters*, and other equipment/components of a *pool* filtration system can operate under pressure. If not correctly installed they can cause serious personal injuries and even death.
- ⚠ Packaging materials are not children's toys. Films can be hazardous and cause suffocation.
- ⚠ Do not drink alcoholic beverages before, after and while swimming. Alcohol consumption may cause drowsiness, loss of consciousness and consequent drowning.
- ⚠ If taking drugs that induce drowsiness (i.e.: tranquillizers, antihistamines or anticoagulants), avoid swimming in heated *pools*.
- ⚠ Prolonged immersion in hot water may cause hyperthermia¹, while immersion in cold water may cause hypothermia², with symptoms such as: Dizziness, fainting, drowsiness, lethargy³. Consequences of hyperthermia and hypothermia may be: Unawareness of imminent danger, lack of heat or cold perception, failure to recognise the need to exit the *pool*, physical inability to exit the *pool*, damages to foetus for pregnant women, unconsciousness with consequent drowning risks.
- ⚠ Do not use the *pool* if the product (*filter/pump*) cannot be used.
- ⚠ In order to protect the users' health do not use the *pool* immediately after treating the water, wait for a length of time compliant with the current health regulations.

¹ Increase in body temperature over physiological limits, maximum limit 37 [°C].

² Decrease in body temperature over physiological limits, minimum limit 35 [°C].

³ State of inactivity or lack of reactivity that nears unconsciousness.

2.3 Contacts and useful addresses.

Information at:

- Shott International srl +39 049 9401150.
- www.shott.it.

3 Product presentation.

3.1 Product scope.

These *filters* (product) are the most reliable nowadays in the market for the cleaning and the maintenance of your domestic swimming pool. They find their application from children to professional's aboveground pools. Each model is provided of a multifunctional *multifunctional valve* that allows the application of the product in many different ways. In particular the *filters* do not need special maintenance operations because working directly on the *multifunctional valve* they allow their deep cleaning with no need of long and exhausting operations.

3.2 Composition.

See Fig. 7.

#		#	
1	Multifunctional valve	5	Drain Tap
2	Soft O-ring for the sealing between the multifunctional valve and the tank	6	Tank
3	Closing flange	7	Tube with body diffuser
4	Funnel	8	Finger

Tab. 1

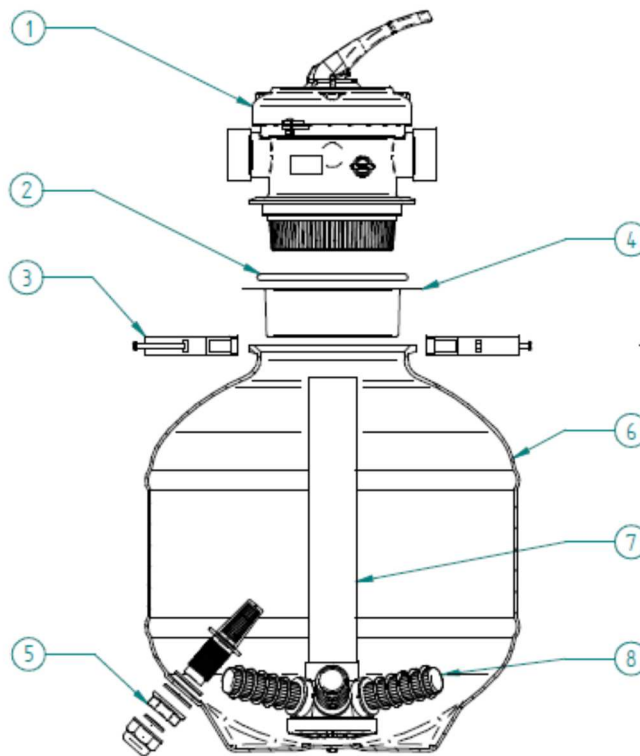

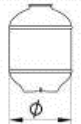







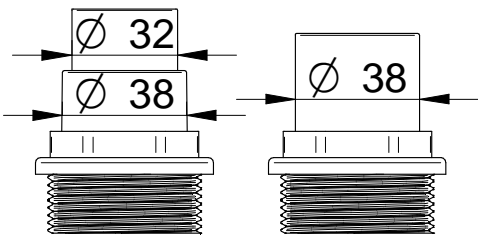
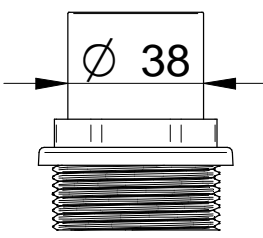

Fig. 7

4 Technical specifications and features.

See Tab. 2.

The *hydraulic parts* used for the building of the system which shall include the product modify the performance (*head and flowrate*) of the *pump*.

	SF15	SF25	SF30	SF38	SF45	SF60	SF65	SF85	SF200
 Lt	15	25	30	38	45	60	65	85	200
 [mm]	389	380	500	520	430	599	530	650	780
 [mm]	252	334	306	334	396	396	476	476	646
 [m ²]	0.04	0.07	0.07	0.07	0.12	0.12	0.17	0.17	0.36
 Ø [mm]	0.4 – 0.8								
 KG Cu ⁴	13-15	18-20	20-25	20-25	25-30	40-50	50-60	75-80	150-160
S ₈₀ [µm] ⁵	<1.75								
C _r [g] ⁶	≥45								
 [m ³]	(<20)	(20-30)	(20-35)	(25-45)	(35-45)	(45-55)	(45-55)	(60-70)	(80-100)
 [l/h]	4000	4000	5500	4000	6000	6000	8500	12000	18000
 [m]	10	10	20	10	20	20	20	20	20
 filter [bar]	(0.2-0.4)								
 backwash [bar]	(0.7-1.1)								
IN/OUT									

Tab. 2

⁴ Uniformity coefficient (EN).

⁵ Filtration threshold (EN). Depending on the sand used.

⁶ Retention capacity (EN). Depending on the sand used.

5 Installation.

5.1 Necessary tools.

See Fig. 8.



Fig. 8

5.2 Storage features and conditions.

The product must be stored in a dry place, protected from weather.

5.3 Transport.

⚠ Handle the product with care to avoid damages.

5.4 Handling.

⚠ Be really careful when moving the product (full of *filter media*, sand) because it is very heavy.

5.5 Positioning.

The product must be positioned *under head*.

The product must be placed in an area not subject to flooding.

The product cannot be used on the water surface.

⚡ The product must always be located at least 3.5 [m] from the edge of the *swimming pool* from which water is drawn (Fig. 9).

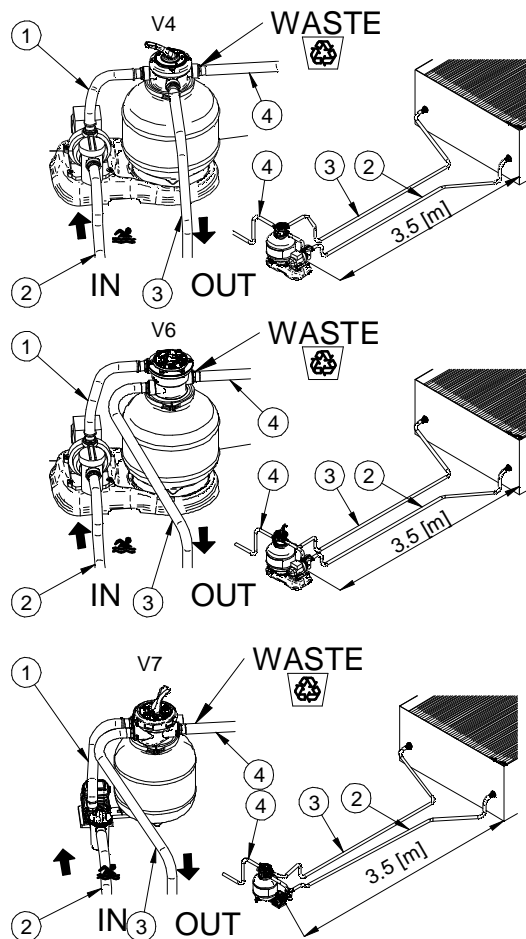

Fig. 9

It is advisable to take the following into account:

- Dimensions and position of *hydraulic parts*.
- Necessary clearance.
- Supply cord position (*pump*).
- Location of the power supply (*power outlet*).
- Support and its location.
- The product must be accessible after installation.

Please remember that water must be conveyed to the product through an appropriate *pump* (Fig. 10).

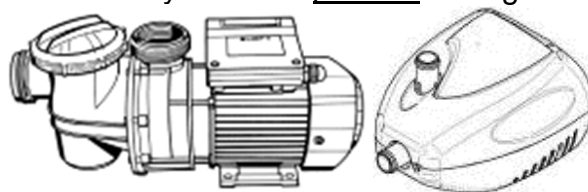

Fig. 10

Make sure the product is positioned in a place where noise generated during normal operations does not create disturbances.

The product must run in a horizontal position. Make sure its position is not altered once it is correctly placed.

The product must be positioned in a shady and aerated place.

5.6 Connections and start-up.

⚠ The product must be installed and operated by individuals with appropriate training.

5.6.1 Drain Tap assembling.

Before mounting the product assemble the special water drain tap. (Fig. 11).

The components that form the drain tap are:

- | | |
|--|-------------------|
| 9. Tap Body. | 11. Closing Ring. |
| 10. Tap's O-Ring couple. One is to be applied internally and the other one externally. | 12. Lid's O-Ring. |
| | 13. Lid. |

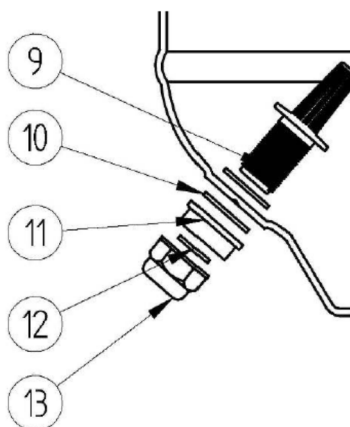

Fig. 11

5.6.2 Filter assembling.

Once the drain tap is mounted on the tank paying attention that all the o-ring are well applied you can proceed with the *Filter* assembling.

1. Insert diagonally the tube with the diffuser body inside the *filter* as shown in the Fig. 12 and subsequently mount the plugs on the diffuser body.

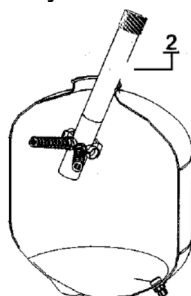

Fig. 12

2. Place the diffuser complete with the tube underneath the tank. Refill the tank with water until the first line you can see on the tank (Fig. 13). This procedure give stability to the diffuser.

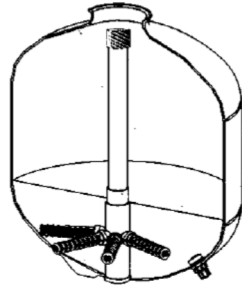

Fig. 13

3. Place the special funnel (Fig. 14, #4) on the tank's mouth, paying attention to cover properly the tube, and start to pour the *filter media* (quartz sand not supplied into the tank, Fig. 15).

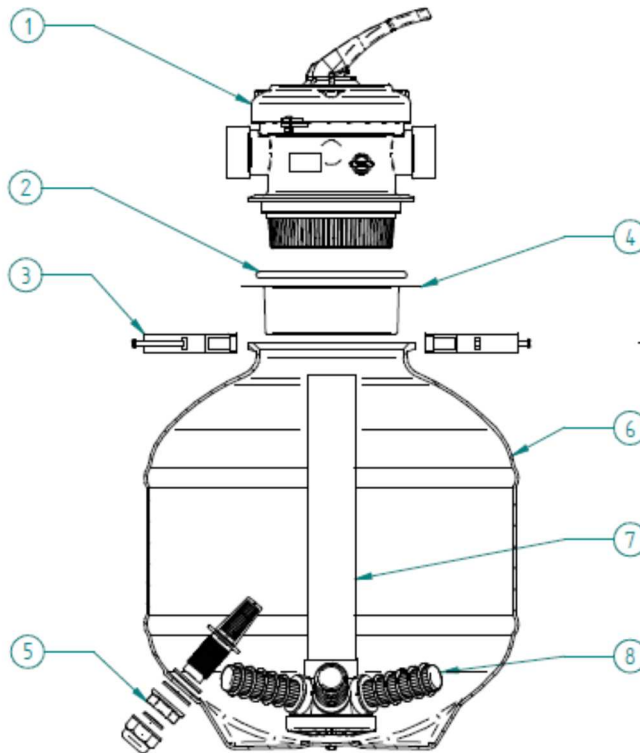

Fig. 14

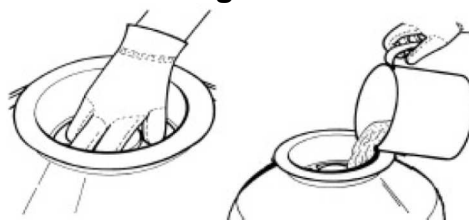

Fig. 15

⚠ Once you refilled the tank with *filter media* until the higher line (around 2/3 of the tank's height) remove the funnel.

4. Take now the special *multifunctional valve* supplied and insert it applying it under the soft o-ring (Fig. 16).



Fig. 16

5. Clean really carefully the tank's neck, place the *multifunctional valve* taking care that the tube enter in the central hole (Fig. 17).

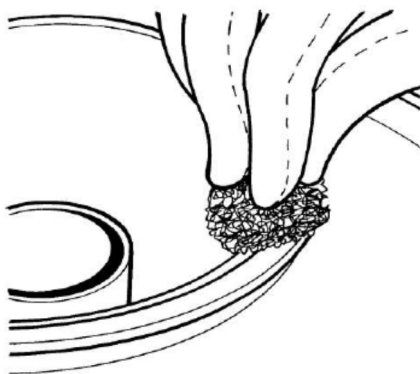

Fig. 17

⚠ Insert the pipe into the central hole, taking care not to move the O-ring from its housing.

6. Now fix the *multifunctional valve* to the tank through the supplied flange (Fig. 18). Work with a screwdriver to tight the screws.

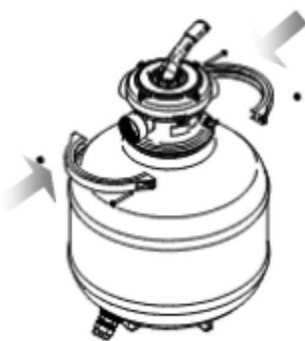

Fig. 18

7. Take off the multifunction white *multifunctional valve* cap, apply some supplied teflon around the manometer (optional for SF15, 25) thread and then screw the manometer with a key using no strength on the plastic box (Fig. 19).

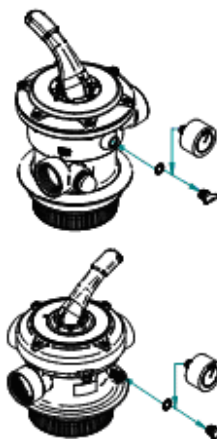

Fig. 19

Now your *filter* is at your disposal.

5.6.3 Pressure connection with compression fittings (optional).

See Fig. 20.

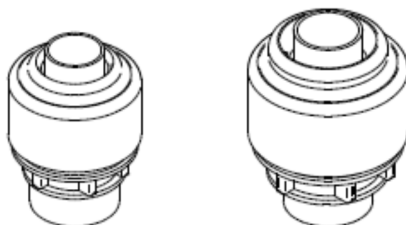
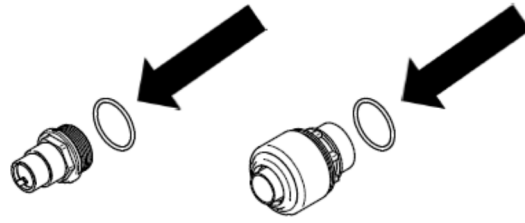

Fig. 20

⚠ Position the O-rings on the hosetail (Fig. 21).

**Fig. 21**

Proceed as follows:

1. Screw the two hosetail (Fig. 22).

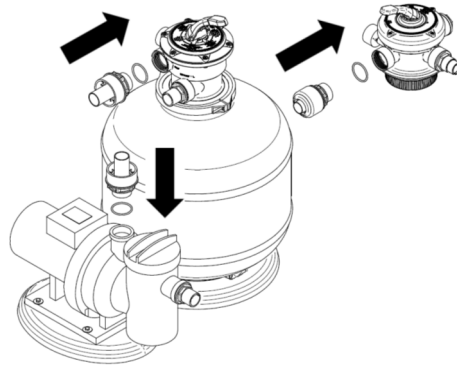
**Fig. 22**

2. Insert onto the hose: ring nut, split ring (Fig. 23)

**Fig. 23**

3. Insert the hose all the way in until it goes no further (Fig. 24)

**Fig. 24**

4. Move all the components forward.

5. Tighten the nut (Fig. 25).

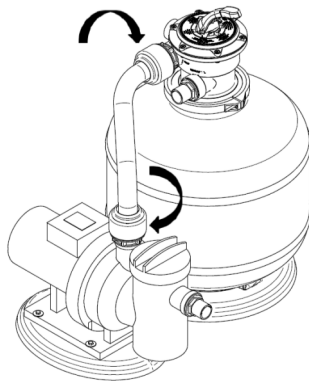

Fig. 25

5.6.4 Connection to the *skimmer* and to the *pump*.

- ⚠ Apply some supplied teflon around the hose connector (*hydraulic parts*) to guarantee a safe sealing.
- ⚠ Position the O-rings on the hosetail (Fig. 26).

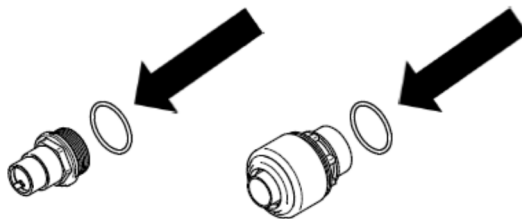

Fig. 26

1. **Pressure connection** (Fig. 30, # 1): join the *filter pump* (outlet Fig. 27, OUT) to the *multifunction valve* (**PUMP**), using the corrugated pipes or the rigid connection (Fig. 28).

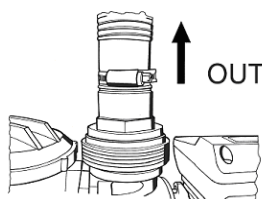

Fig. 27

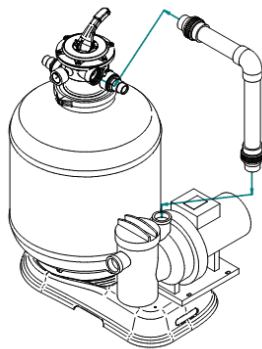

Fig. 28

2. **Skimmer tube** (Fig. 30, # 2): join the *skimmer* connection to the frontal connection of the *filter pump* (inlet Fig. 29, IN).

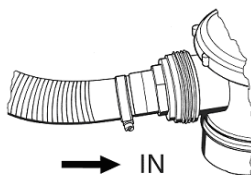

Fig. 29

3. **Return-tube** (Fig. 30, # 3): join the connection on the 4 or 6 ways *multifunctional valve* marked with **RETURN/POOL** to the entrance mouth connection of the swimming pool. Tight with special hose clamps the tubes on the connections (*hydraulic parts*).

4. **Backwash-tube** (Fig. 30, # 4): to be used when we apply the **BACKWASH** function to drain the dirty water in a discharge area. For the connection use proper rubber tubes and proper hose clamps (*hydraulic parts*).

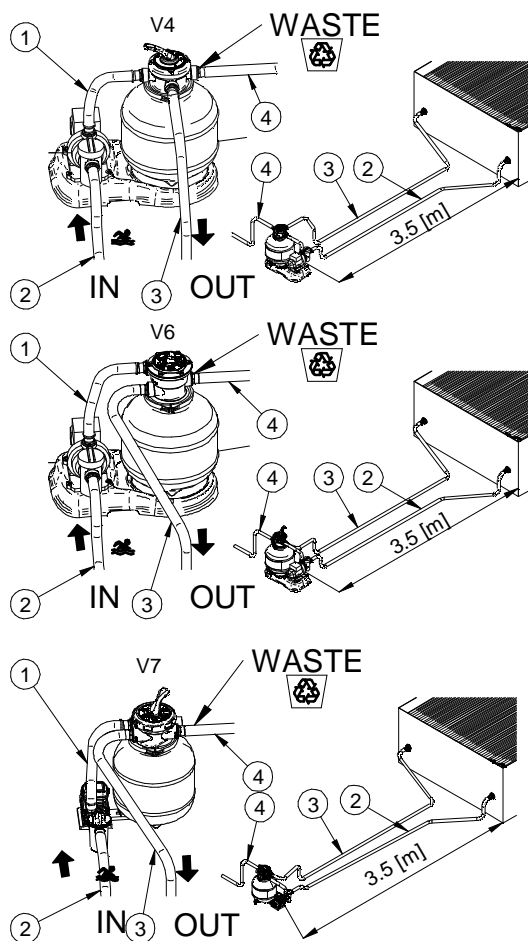

Fig. 30

5.6.5 Refilling the swimming pool.

If you have already connected everything properly you can now start to refill the *swimming pool*. The water level must reach at least the middle of the *skimmer's* suction mouth.

5.6.6 Starting the product.

⚠ Before starting the application of the *filter* make sure this one is well positioned out of the *swimming pool* under the water level (*flooded*). Check that all the tubes and joints are fixed tightly. The *swimming pool* has to be refilled with water until half of the *skimmer* height. The water must arrive to the *pump* by natural flow (*flooded*).

1. Change the 4 or 6 ways *multifunctional valve* lever to the **BACKWASH** position.

⚠ Make sure that on the joint **WASTE** (Fig. 31, # 4) a tube that make the water drain is connected. Start the *filter* only after this moment.

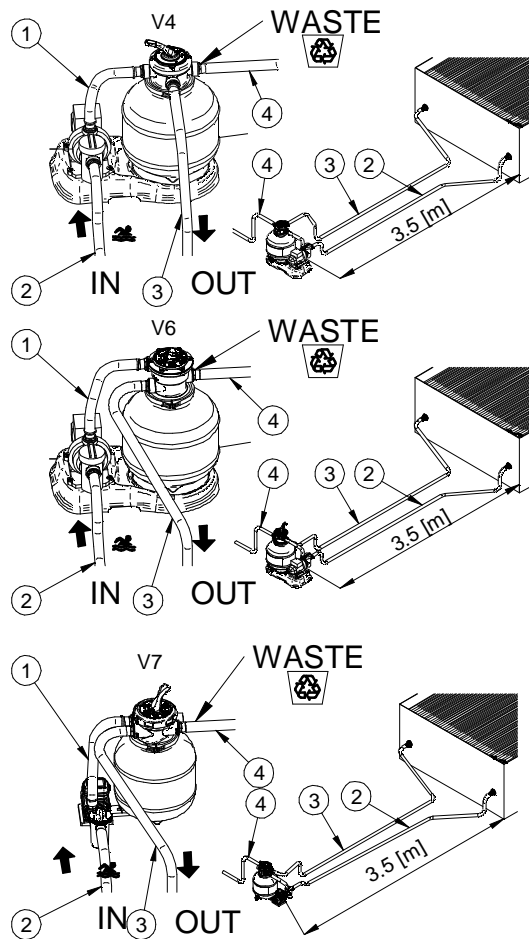

Fig. 31

2. Start the *pump* and make a **BACKWASH** of about 2÷3 minutes.
3. Right after this stop the *pump* and change the *multifunctional valve* lever position on **RINSE**.
4. Re-start the *pump* and rinse for about 30 seconds.
5. Stop the *pump* once again and change the *multifunctional valve* lever position on **FILTER**.
6. Start again the *pump*.

The product is now doing its normal job.

5.7 Reinstallation and reuse.

⚠ Clean the product and the moving parts accurately before stopping the product for a while, such as, for instance, during the winter months. Do not lubricate and/or use detergents and chemical cleaning products.

⚠ If there is the risk of freezing, the product must be carefully emptied from the liquids in its hydraulic circuit. It is advisable to empty all the *hydraulic parts*.

Remove the cap to empty the product (Fig. 32, # 13), when included.

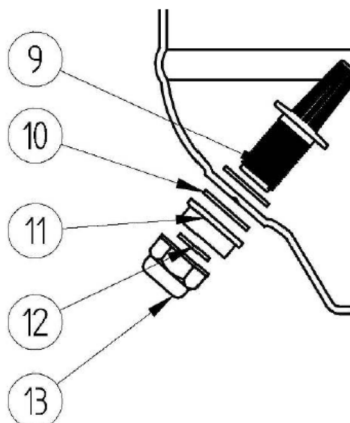

Fig. 32

5.8 Demolition and disposal.

Collecting recyclable material, both those used for packaging (cardboard, nylon, etc.) and those replaced during routine and extraordinary maintenance is recommended. Suitable collection of waste material for recycling, processing and environmentally compatible disposal contributes in avoiding possible negative effects on the environment and health and promote the reuse and/or recycling of product materials.

⚠ Illicit product disposal by the user may be punishable by current international and/or national laws.

6 Operations and use.

⚠ Do not use glues, sealers or other chemical products on threads or other parts of the product.

6.1 Description of operation.

The product you have purchased carries out the mechanical purification of the water that, passing through the *filter media* (sand), is cleaned of all undissolved substances held back by the *filter media*.

6.2 Application range.

The product cannot be used to purify water for human consumption.

⚠ The product was designed and constructed to operate in above-ground fresh swimming *pool*, located outdoors.

6.3 Use.

⚠ The product cannot be used to purify water for human consumption.

6.4 Operating limits and environmental limits.

- Maximum water temperature: 35 [°C].
- Minimum water temperature: 4 [°C].

7 User instructions.

7.1 Foreseen use and adjustments.

We suggest to start the *filter* twice a day for 4 or 5 hours.

Regularly check if backwash is necessary, please see Tab. 2.

7.1.1 Use and functioning of the *multifunctional valve*.

⚠ Always switch off the *pump* when operating on the *multifunctional valve's* lever.

⚠ It is recommended to install valves in the *inlet* and *outlet* pipelines (*hydraulic parts*).

	V4	V6	V7
<p>FILTRATION. The water in the <i>pool</i> enters the <i>multifunctional valve</i> from the PUMP connector (Fig. 33, # 1), travels through the <i>filter media</i> (from top to bottom), exits from the POOL connector (Fig. 33, # 3) and returns clean to the <i>pool</i>.</p>			
<p>BACKWASH. The water in the <i>pool</i> enters the <i>multifunctional valve</i> from the PUMP connector (Fig. 33, # 1), travels through the <i>filter media</i> (from bottom to top) stirring it, exits from the WASTE connector (Fig. 33, # 4) getting rid of the impurities</p>			
<p>RINSE. The water in the <i>pool</i> enters the <i>multifunctional valve</i> from the PUMP connector (Fig. 33, # 1), travels through the <i>filter media</i> (from top to bottom) compacting it, exits from the WASTE connector (Fig. 33, # 4) getting rid of the impurities</p>			
<p>VALVE CLOSED (only on 6-way <i>multifunctional valve</i>). The water in the <i>pool</i> does not cross the <i>filter</i>. The PUMP connector (Fig. 33, # 1) is closed.</p>	-		
<p>WASTE (only on 6-way <i>multifunctional valve</i>). The water in the <i>pool</i> enters the <i>multifunctional valve</i> from the PUMP connector (Fig. 33, # 1), exits straight from the WASTE connector (Fig. 33, # 4) without going through the <i>filter media</i>.</p>	-		
<p>CIRCULATION (only on 6-way <i>multifunctional valve</i>). The water in the <i>pool</i> enters the <i>multifunctional valve</i> from the PUMP connector (Fig. 33, # 1) and exits from the POOL connector (Fig. 33, # 3) going back to the <i>pool</i> without crossing the <i>filter media</i>.</p>	-		
<p>WINTER. Rest position of the <i>multifunctional valve</i> to protect the internal components of the <i>multifunctional valve</i> itself. Position suitable for storage.</p>			

Tab. 3

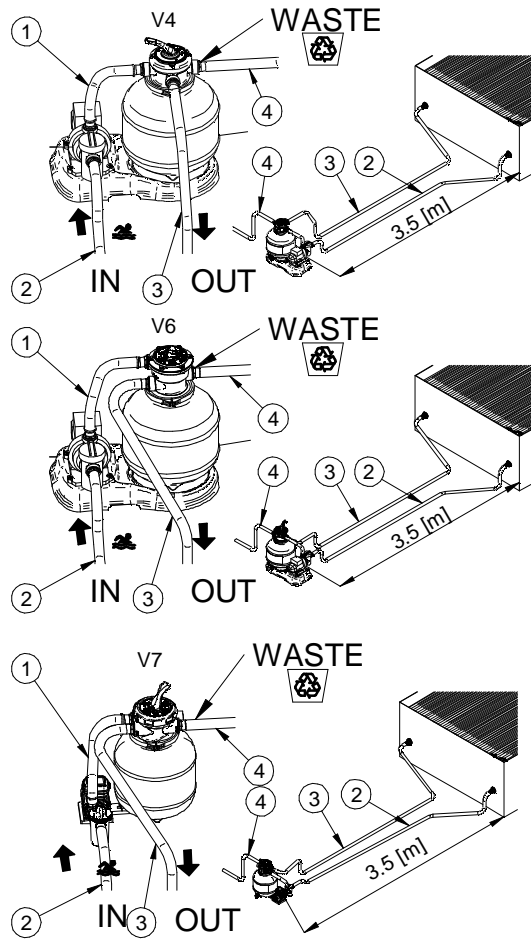

Fig. 33

8 Routine, scheduled and extraordinary maintenance.

⚡ Before proceeding with any maintenance activity, remember to disconnect the *power plug* from the *power outlet*, and not to put your hands in the water if the product (*pump*) is turned on.

⚠ Do not lubricate and/or use detergents and/or chemical products to clean the product.

Replace damaged components and/or deteriorated as quickly as possible, use only original spare parts. For this purpose, please consult the "Retail and spare parts and relevant documentation".

8.1 Routine maintenance.

To be performed at least once a year, or more frequently if necessary.

The *filter* maintenance is limited to its own cleaning through the **BACKWASH**. Start it at least once a week for 2-3 min. and after each bottom cleaning.

⚡ Carry out a **BACKWASH** after each cleaning of the bottom or when the pressure on the gauge equals the pressure stated in Tab. 2 (backwash).

⚠ A rinse of about 30 seconds must follow each **BACKWASH**.

It is essential to *filter* twice a day for 4-5 hours, to regularly backwash (for 2÷3 minutes) and to wash the pool bottom at least once a week so that the pool water remain cleaned!

Product components that, due to their normal use, suffer wear and/or tear must be regularly replaced to ensure good product performance. The following table shows the perishables and/or consumables used in the product and their estimated working life.

0 rings and general seals	1 year
---------------------------	--------

Tab. 4

8.1.1 Cleaning the *filter media* (*filter backwash*).

1. Change the 4 or 6 ways *multifunctional valve* lever to the **BACKWASH** position.
2. Start the *pump* and make a backwash of about 2÷3 minutes.
3. Right after this stop the *pump* and change the *multifunctional valve* lever position on **RINSE**.
4. Re-start the *pump* and rinse for about 30 seconds.
5. Stop the *pump* once again and change the *multifunctional valve* lever position on **FILTER**.
6. Start again the *pump*.

8.1.2 Bottom cleaning.

To wash the bottom the *multifunctional valve* on the *filter* must be on **FILTER** position. The tool for the bottom cleaning must be connected to the *skimmer* with a flexible tube. The *pump* must be switched off.

⚠ Completely refill with water the tube that is connected to the tool for the bottom cleaning so that the *pump* cannot aspire air. No air must enter the *filter*. If there is air switch off the *pump* and empty the air from the suction tool.

Slowly move the tool and clean in this way all the bottom. The *filter* systems with no pre-*filter* work with a basket *skimmer*!

You can proceed with the bottom cleaning using the proper tools even on **WASTE** position (only on the 6 ways *multifunctional valve* version) to take off all impurities (for example seaweeds) that otherwise could pass again through the *filter's* sand.

8.1.3 Wintering.

Wintering: Empty out any remaining water in the device, clean accurately (no detergents or chemical products), store it in a dry place and shelter from bad weather. Change the 4 or 6 ways *multifunctional valve* lever to the **WINTER** position.

8.2 Extraordinary maintenance.

This consists in replacing worn or damaged parts (*multifunctional valve*, drain tap, tank, etc.).

8.2.1 Multifunctional valve cleaning.

See Fig. 34, Fig. 35, Fig. 36.

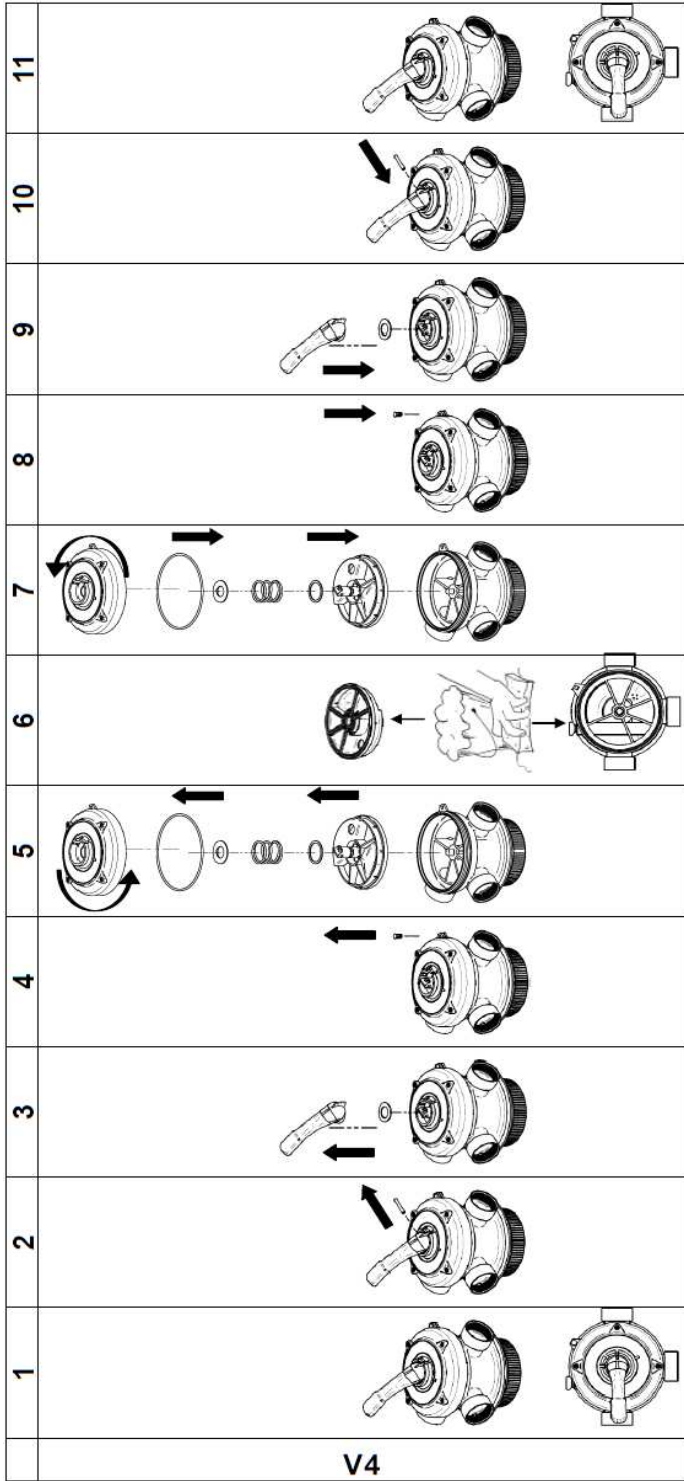

Fig. 34

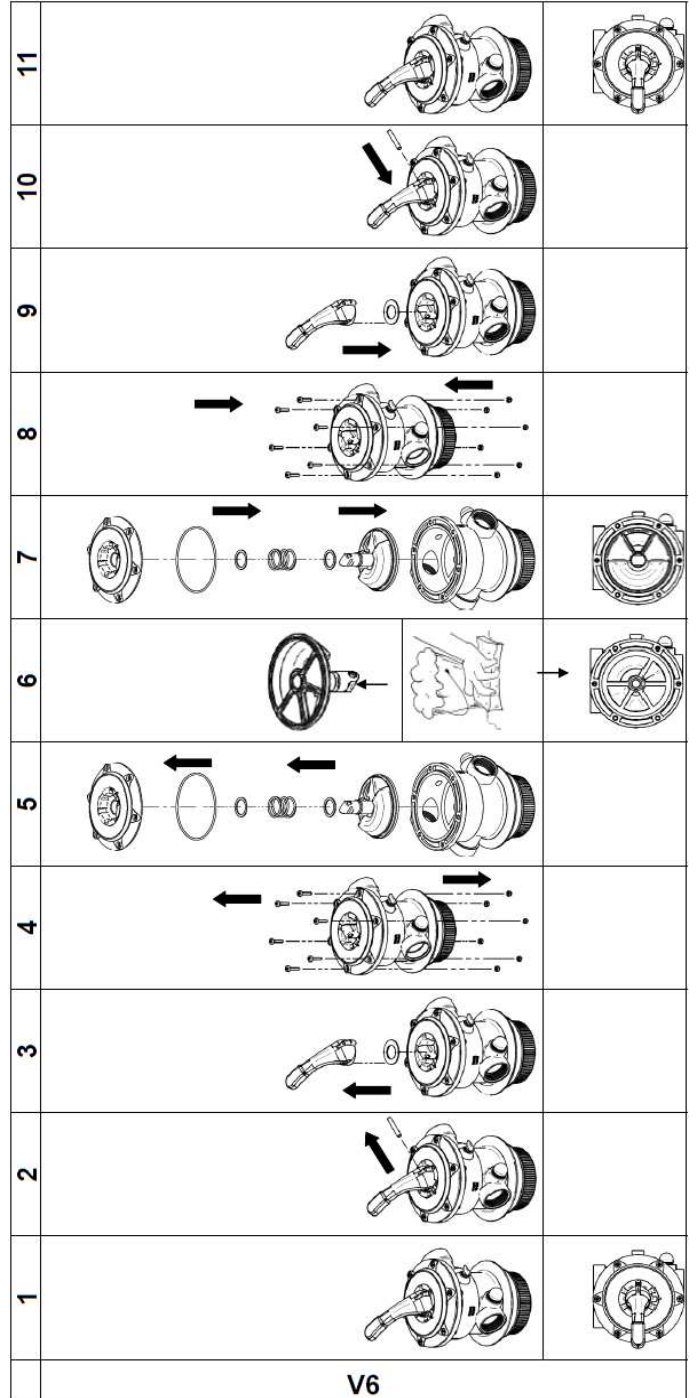

Fig. 35

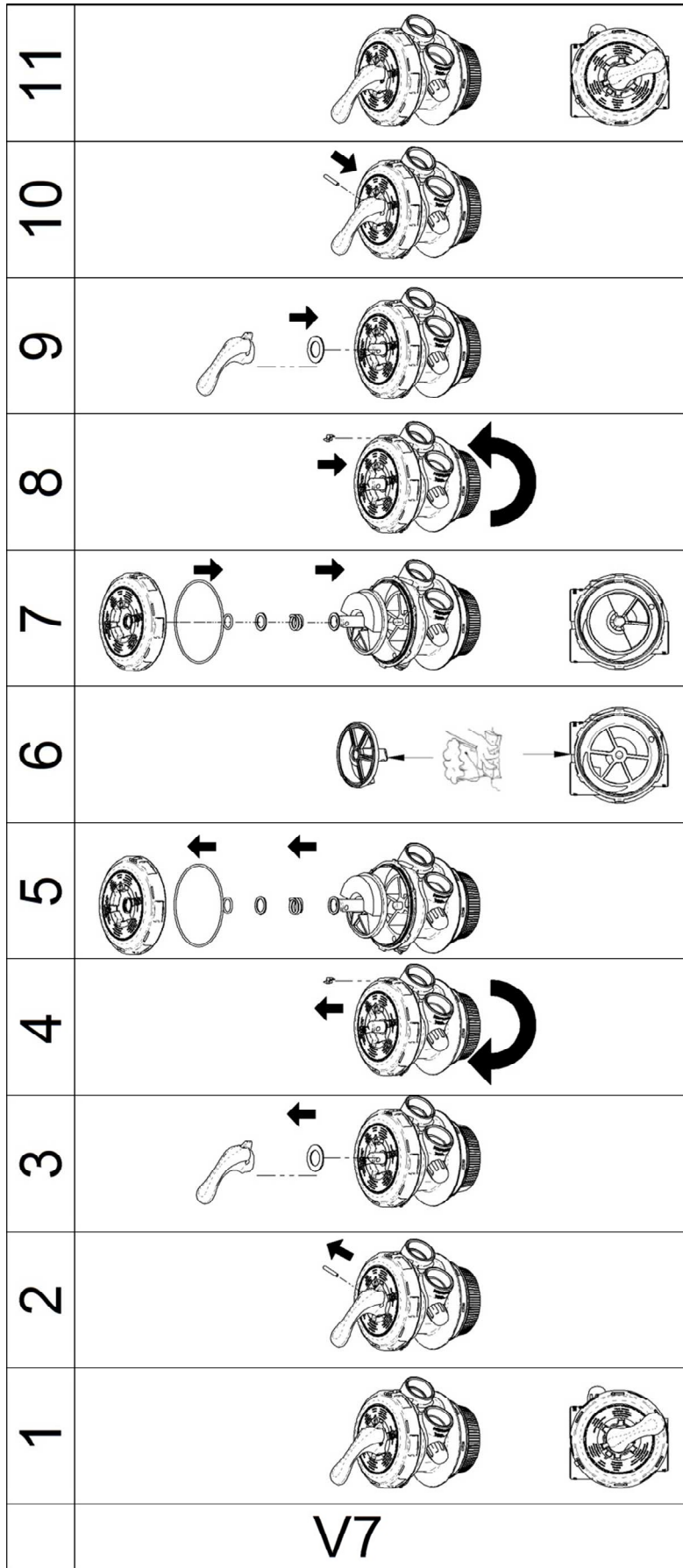

Fig. 36

9 Troubleshooting.

PROBLEM	CAUSE	1 ST SOLUTION	2 ND SOLUTION
1. Low flowrate from outlet	The <u>product</u> is dirty	Clean the <u>product</u> .	Please consult a skilled technician.
	<i>The hydraulic parts</i> are obstructed or bent.	Fix the <i>hydraulic parts</i> .	
	The <i>pump</i> has not been primed correctly.	Prime the <i>pump</i> .	
2. The <u>product</u> does not work.	Power supply absent or insufficient.	Check the presence of a power supply.	Please consult a skilled technician.
	<i>The hydraulic parts</i> are obstructed or bent.	Fix the <i>hydraulic parts</i>	
3. Damaged plastic components.	Wear.	Replace.	Please consult a skilled technician.
4. Water leak	Gaskets or o-rings incorrectly installed	Check correct gasket and o-ring installation.	Please consult a skilled technician.
5. Sand inside the pool.	It is normal to have a little sand inside the pool after it run for a while. After a first bottom cleaning this problem should be solved.	Clean the bottom.	Please consult a skilled technician.
6. Sand even after the first bottom cleaning.	Sand type too thin.	Make sure the quality of the sand you purchased it is suitable for this kind of job.	Please consult a skilled technician.
7. Water leakage from the draining pipe.	The tap ring nut is not tightened properly.	Make sure the pipe o-ring is well fixed.	Please consult a skilled technician.
8. Too much pressure.	Blocked <i>filter</i> .	Clean the <i>filter media</i> .	Please consult a skilled technician.
	<i>The hydraulic parts</i> are obstructed or bent.	Fix the <i>hydraulic parts</i>	
9. Cleaning cycles needed more and more closer.	Presence of seaweeds.	Check the eventual presence of seaweeds in the pool and if needed add a disinfectant or a PH level corrective.	Please consult a skilled technician.
10. The pool water is never bright.	<u>Product</u> not suitable to the application.	Check the <i>filter</i> and/or the <i>pump</i> are the right size for the <i>pool</i> used.	Please consult a skilled technician.

10 Retail and spare parts and relevant documentation.

See Tab. 5 refer to Fig. 37, Fig. 38, Fig. 39, Fig. 40, Fig. 41.

△ Replace any damaged and/or worn components as quickly as possible; use only original spare parts.

#	SF15 PPF15	SF25 PPF25	SF30 PPF30	SF38 PPF38	SF45 PPF45	SF60 PPF60	SF65 PPF65	SF85 PPF85	SF200 PPF200
1	XR901N04 (V4) XR901N06 (V6) XR901N07 (V7)								
2	XR900I (∅ 32/38 [mm]) XR900I38 (∅ 38 [mm])								
3	XR379I								
4	XR902N20								
6	XR380I								
7	XR378I								
8	XR903S								
9	1140060	XR929N	1140014	1140059	XR924N	1140016	XR925N	XR926N	XR927N
10a	XR624I (∅ 32 [mm], l=0.52 [m]) XR624I45 (∅ 32 [mm], l=0.45 [m]) XR625I58 (∅ 38 [mm], l=0.58 [m]) XR625I77 (∅ 38 [mm], l=0.77 [m]) 1100033 (∅ 38 [mm], l=0.78 [m])								
10b	XR670I85NN (SF85/PP10000) XR670I65MS (SF65/SP8000) XR670I65MN (SF65/PP8000)								
11	XR920S								
12+13	XR910I25	XR910I25	XQ615I30	XR910I65	XR910I45	XQ615I60	XR910I65	XR910I85	XR910I20
14a	XR355I68 (SP4000, PP4000/6000) XR355I10 (SP6000/8000, PP8000/10000)								
14b	XR940I								
14c	XR942I								
14d	XR941I								
14e	XR355I40								
14f	XR948I								
14g	XR947I								
14f+14g	XR949N								
14h	1140063								
23	1100031 (∅ 32 [mm]) 1100032 (∅ 38 [mm])								

Tab. 5

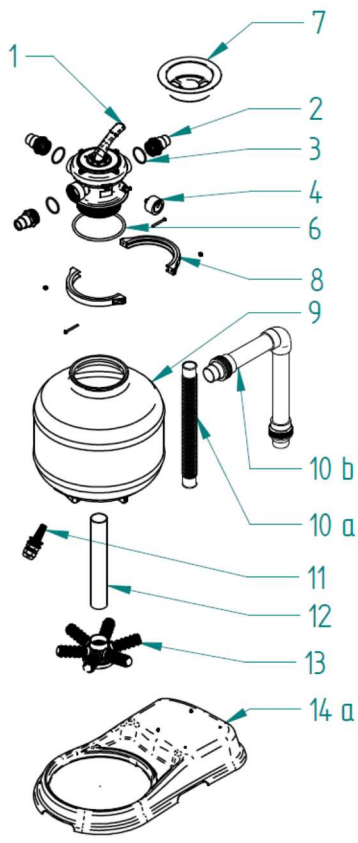

Fig. 37

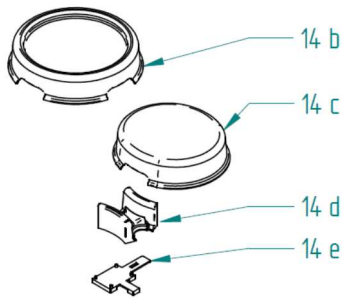

Fig. 38

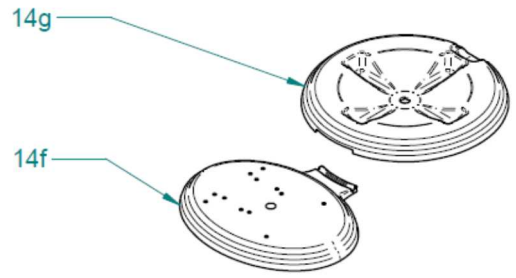

Fig. 39

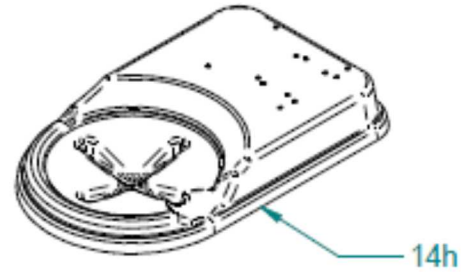
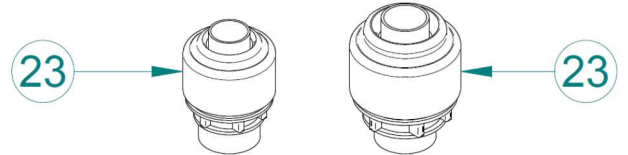

Fig. 40

\varnothing 38 [mm]



\varnothing 32 [mm]

Fig. 41

⚠ Replace any damaged and/or worn components as quickly as possible; use only original spare parts.



SHOTT INTERNATIONAL S.R.L.
VIA DELLE PEZZE, 35
35013 CITTADILLA (PD) - ITALY
TEL. +39 049-9401150
FAX. +39 049-9409140
E-MAIL: info@shott.it
WEB: www.shott.it